

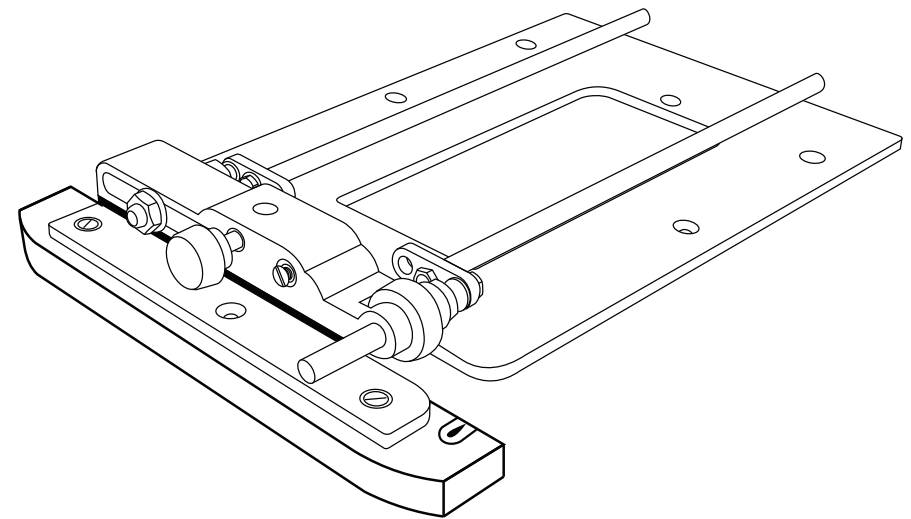

CRB7 - PARALLEL SIDE FENCE KIT



INSTRUCTION MANUAL



Manufactured by MPOWER Tools Ltd

Tel: 0044 (0)1980 629 526
Email: technical@m-powertools.com
Email: customercare@m-powertools.com
Web: www.mpower-tools.com

Manor Farm Reserve - Newton Tony - Salisbury - Wiltshire - SP4 0HA - UK

© Copyright MPOWER Tools Ltd 2020



FREE 5 YEAR EXTENDED WARRANTY

Register Online
mpower-tools.com/warranty

CRB7 PARALLEL SIDE FENCE

Thank you for purchasing MPOWER's Parallel Side Fence which should give lasting performance if used in accordance with these instructions.

The following symbols are used throughout these instructions denoting risk of personal injury, loss of life or damage to the tool in case of non-observance of the instructions.

Refer to the instruction manual of your power tool.

INTENDED USE

The Parallel Side Fence has been designed for use with MPOWER's Combination Router Base (CRB7), a router, and a suitable router cutter when performing edge parallel rebates and edge moldings.

This accessory combined with the fine adjustment of the CRB7 will improve control and offer greater edge to rebate range whilst achieving an excellent finish.

This accessory can be used as a replacement for the much larger and more complicated traditional fences supplied with many makes and models of router.

SAFETY

Please read and understand the safety points at the end of this instruction as well as the power tool instructions before use.

Please keep these instructions in a safe place. Users must be competent in safe routing practices before using this product.

ITEMS REQUIRED

- CRB7 Router Base
- Router with suitable collet fitted.
- Flat head screwdriver
- 5/16" (8mm) drill bit.
- 1/2" (12mm) drill bit.
- Hand tools.
- Suitable router cutter

ITEMS ENCLOSED – (See Fig 1)

- 1) 1x Machined solid Parallel Side Fence (SKU 40051)
- 2) Internal Pack 10/20 (SKU 40075)
2x 25/64" (10mm) CS machine fixing screws.
2x 3/4" (20mm) CS machine screws,

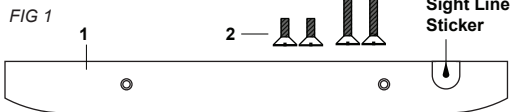

SIDE FENCE FIXING POSITIONS

The Side Fence can be mounted in different locations on the underside of the CRB7 Base Plate (See Fig 2).

FIG 2

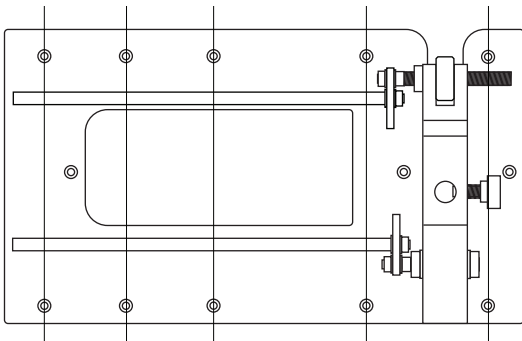

The Side Fence fixing position is determined by the desired distance of the routing pass from the edge of the workpiece (See Fig 3)

Note: Dimensions may vary according to the size and shape of the router base being used.

*distance between the cutter centre and the edge of the workpiece.

FIG 3

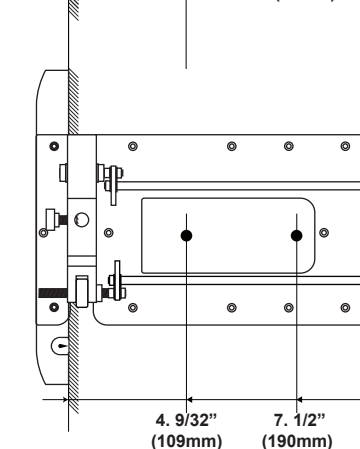
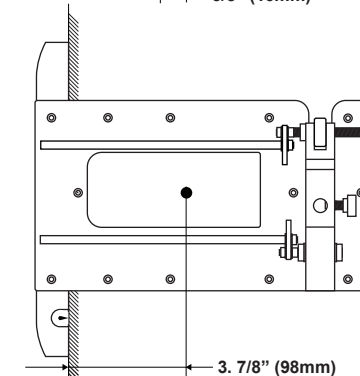
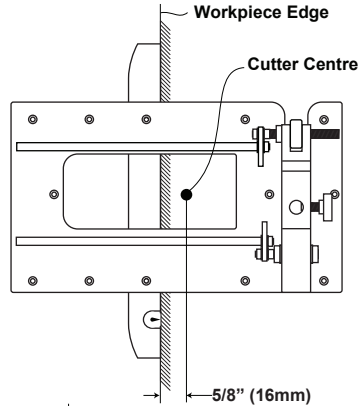

ASSEMBLY

FITTING THE SIDE FENCE – (See fig 4)

After deciding on the Fence fixing position slide the router off the CRB7 rods.

Place the fence under the base plate so that the 2x brass threaded inserts of the fence line up under the chosen countersunk holes in the top surface of the base plate.

Fit the 2 x 25/64" (10mm) CS machine screws.

Do not over tighten.

FIG 4

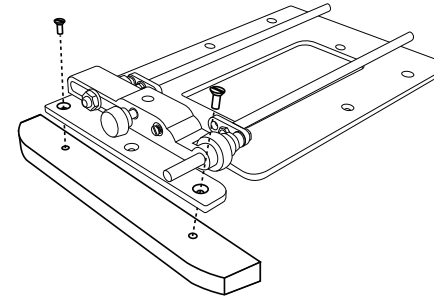

Slide the router back onto the CRB7 rods and position it in the approximate area of the desired router pass.

Fine adjustment of the cutter position can then be carried out using the Micro Adjuster on the CRB7 (please see the CRB7 instruction manual for further details on this process)

WARNING: When edge moulding only a section of the router cutter may be revealed to the workpiece edge, meaning the back side of the cutter will cut into the face of the fence. Rather than permanently damaging the fence; fit an additional sacrificial fence.

FITTING A SACRIFICIAL FENCE TO THE SIDE FENCE

We recommend making the sacrificial fence from solid hardwood, however ply or MDF will work.

Cut and machine the sacrificial fence to 12 x 1.3/8 x 7/8" (300 x 35 x 20mm), (Dimensions can vary according to the users needs or preference).

Ensure the sacrificial fence is machined flat then lightly sand the edges to remove any splinters.

Accurately mark out the drilling locations for the 2x fixing holes by:

Measuring and marking a parallel line 9/32" (7mm) in from the top edge of the sacrificial fence.

Measure and mark the centre point of the sacrificial fence mid way down the parallel line. Then place it under the baseplate end drillings. So that the parallel line can be seen through the drillings. Using a sharp pencil draw through the drillings, marking the position of the fixing holes (see Fig 5)

FIG 5

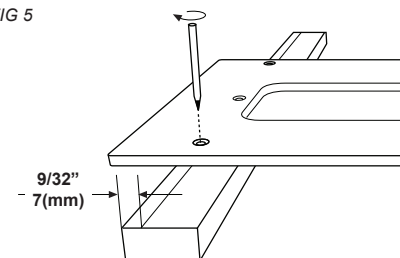

Through drill the 2x fixing holes using a 3/16" (5mm) drill bit.

Counter bore the outer/top surface of the 2x fixing holes depth 19/64" (7.5mm) use a 3/8" (10mm) drill bit.

IMPORTANT: The counter bore depth must allow the 3/4" (20mm) CS machine screws to locate fully* into the machine inserts of the Fence.

*Fully located = 13/64" (5mm) of the CS Machine Screw thread. (See fig 6)

FIG 6 (not to scale)

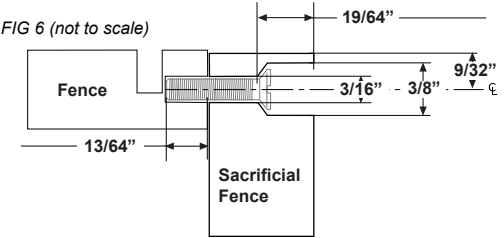

Note: The counter bores allow the fixing screw heads to sit well below the sacrificial fence surface when fitted to the fence.

Attach the Sacrificial Fence to the CRB7 Fence using the 2x 3/4" (20mm) screws. (See fig 7)

FIG 7

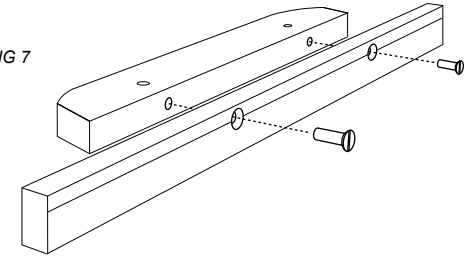

The CRB7 Sacrificial Fence is now fitted and ready to be used.

SPARE PARTS

Fence Assembly	40051
Internal Pack 10/20	40075

MAINTENANCE

Continual satisfactory operation depends upon proper tool care and regular cleaning.

Cleaning: Regularly clean accessory with a soft cloth.

Lubrication: Your accessory requires no additional lubrication.

ENVIRONMENTAL PROTECTION

Re-cycle raw materials instead of disposing as waste.

Packing should be sorted for environmental-friendly recycling.

The product and its accessories at the end of its life should be sorted for environmental-friendly recycling.

GUARANTEE

All MPOWER products are guaranteed against any defect in either workmanship or material, except products that have been damaged due to improper use or maintenance.

© MPOWER Tools Ltd. 2019

Our policy of continuous improvement means that specifications may change without notice. MPOWER Tools Limited cannot be held liable for any material rendered unusable, or for any form of consequential loss.